

Selection diagram

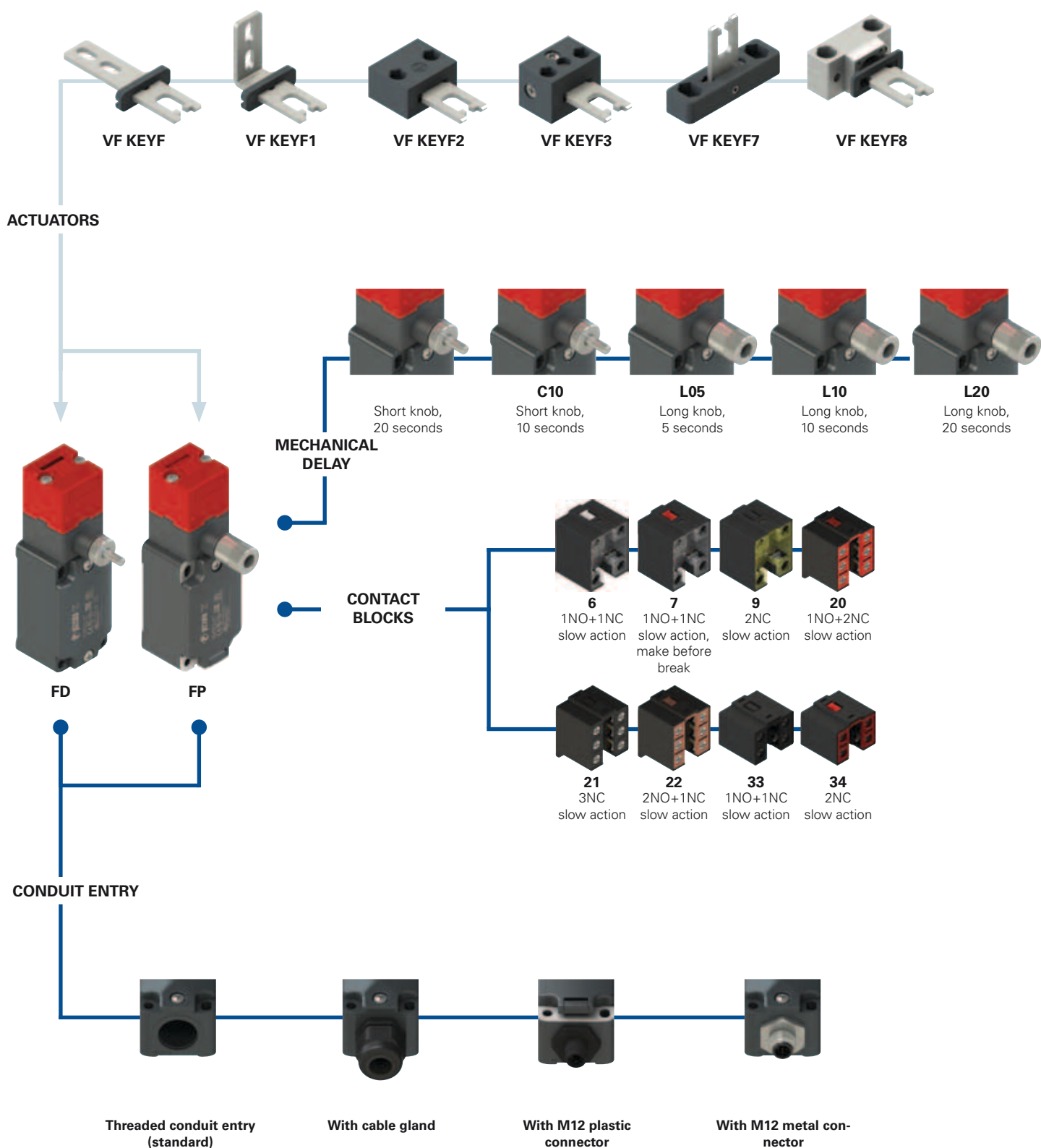

**Code structure****Attention!** The feasibility of a code number does not mean the effective availability of a product. Please contact our sales office.

article
options
options

FD 6R2-L10F1GM2K50T6

| Housing | |
|-----------|----------------------------------|
| FD | metal, one conduit entry |
| FP | technopolymer, one conduit entry |

| Contact block | |
|---------------|---|
| 6 | 1NO+1NC, slow action |
| 7 | 1NO+1NC, slow action, make before break |
| 9 | 2NC, slow action |
| 20 | 1NO+2NC, slow action |
| 21 | 3NC, slow action |
| 22 | 2NO+1NC, slow action |
| 33 | 1NO+1NC, slow action |
| 34 | 2NC, slow action |

| Mechanical delay | |
|------------------|-----------------------------|
| | short knob, 20 s (standard) |
| C10 | short knob, 10 s |
| L05 | long knob, 5 s |
| L10 | long knob, 10 s |
| L20 | long knob, 20 s |

| Actuators | |
|-----------|--|
| | without actuator (standard) |
| F | straight actuator VF KEYF |
| F1 | angled actuator VF KEYF1 |
| F2 | jointed actuator VF KEYF2 |
| F3 | jointed actuator adjustable in two directions VF KEYF3 |
| F7 | jointed actuator adjustable in one direction VF KEYF7 |
| F8 | universal actuator VF KEYF8 |

| Ambient temperature | |
|---------------------|----------------------------|
| | -25°C ... +80°C (standard) |
| T6 | -40°C ... +80°C |

| Pre-installed cable glands or connectors | |
|--|--|
| | no cable gland or connector (standard) |
| K23 | cable gland for cables Ø 6 ... 12 mm |
| ... | |
| K50 | M12 metal connector, 5-pole |
| ... | |

For the complete list of possible combinations please contact our technical department.

| Threaded conduit entry | |
|------------------------|--------------------|
| M2 | M20x1.5 (standard) |
| | PG 13.5 |

| Contact type | |
|--------------|--|
| | silver contacts (standard) |
| G | silver contacts with 1 µm gold coating |
| G1 | silver contacts, 2.5 µm gold coating (not for contact blocks 20, 21, 22, 33, 34) |

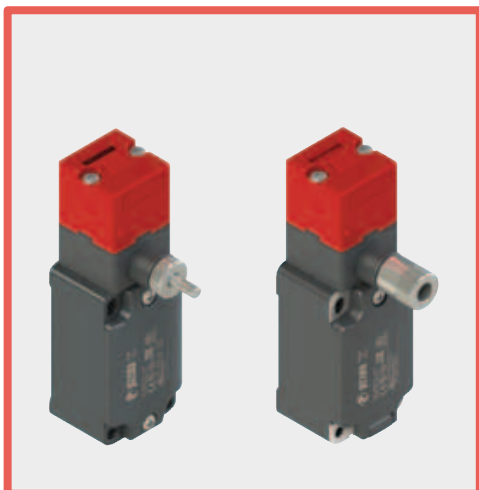

Main features

- Metal housing or technopolymer housing, one conduit entry
- Protection degree IP67
- 8 contact blocks available
- 6 stainless steel actuators available
- Versions with assembled M12 connector
- Versions with gold-plated silver contacts
- Strong actuator locking (1000 N)
- Manual actuator release
- Versions with different release delay times

Quality marks:



| | |
|---------------|--|
| IMQ approval: | EG605 |
| UL approval: | E131787 |
| CCC approval: | 2007010305230000 (FD series) 2007010305230014 (FP series) |
| EAC approval: | RU C-IT.A.135.B.00454 |

Technical data

Housing

FP series housing made of glass fibre reinforced technopolymer, self-extinguishing, shock-proof and with double insulation: 
 FD series: metal housing, baked powder coating.
 One threaded conduit entry: M20x1.5 (standard)
 Protection degree: IP67 acc. to EN 60529 with cable gland of equal or higher protection degree

General data

For safety applications up to: SIL 3 acc. to EN 62061
 PL e acc. to EN ISO 13849-1
 Interlock with mechanical lock, coded: type 2 acc. to EN ISO 14119
 Coding level: low acc. to EN ISO 14119
 Safety parameters:
 B₁₀₀₀: 1,000,000 for NC contacts
 Service life: 20 years
 Ambient temperature: -25°C ... +80°C
 Version for operation at ambient temperatures from -40°C ... +80°C on request
 Max. actuation frequency: 360 operating cycles/hour
 Mechanical endurance: 500,000 operating cycles
 Max. actuation speed: 0.5 m/s
 Min. actuation speed: 1 mm/s
 Maximum force before breakage F_{1max}: 1000 N acc. to EN ISO 14119
 Max. holding force F_{Zh}: 770 N acc. to EN ISO 14119
 Max. clearance of the actuator: 4.5 mm
 Tightening torques for installation: see page 313-324

Cable cross section (flexible copper strands)

Contact blocks 20, 21, 22, 33, 34: min. 1 x 0.34 mm² (1 x AWG 22)
 max. 2 x 1.5 mm² (2 x AWG 16)
 Contact blocks 6, 7, 9: min. 1 x 0.5 mm² (1 x AWG 20)
 max. 2 x 2.5 mm² (2 x AWG 14)

In compliance with standards:

IEC 60947-5-1, EN 60947-5-1, EN 60947-1, IEC 60204-1, EN 60204-1, EN ISO 14119, EN ISO 12100, IEC 60529, EN 60529, BG-GS-ET-15, UL 508, CSA 22.2 No.14 .

Approvals:

IEC 60947-5-1, UL 508, CSA 22.2 No.14 , GB14048.5-2001.

Compliance with the requirements of:

Machinery Directive 2006/42/EC and EMC Directive 2014/30/EU.

Positive contact opening in conformity with standards:

IEC 60947-5-1, EN 60947-5-1.

 If not expressly indicated in this chapter, for correct installation and utilization of all articles see chapter utilization requirements from page 313 to page 324.

| | Electrical data | Utilization category |
|---------------------------------|---|---|
| without connector | Thermal current (I _{th}): | 10 A |
| | Rated insulation voltage (U): | 500 Vac 600 Vdc 400 Vac 500 Vdc (contact blocks 20, 21, 22, 33, 34) |
| | Rated impulse withstand voltage (U _{imp}): | 6 kV 4 kV (contact blocks 20, 21, 22, 33, 34) |
| | Conditional short circuit current: Protection against short circuits: Pollution degree: | 1000 A acc. to EN 60947-5-1 type aM fuse 10 A 500 V 3 |
| with M12 connector 4 and 8-pole | Thermal current (I _{th}): | 4 A |
| | Rated insulation voltage (U): | 250 Vac 300 Vdc |
| | Protection against short circuits: Pollution degree: | type gG fuse 4 A 500 V 3 |
| | | |
| with M12 connector 8-pole | Thermal current (I _{th}): | 2 A |
| | Rated insulation voltage (U): | 30 Vac 36 Vdc |
| | Protection against short circuits: Pollution degree: | type gG fuse 2 A 500 V 3 |
| | | |



Description



These switches are used on machines where the hazardous conditions remain for a while, even after the machine has been switched off, for example because of mechanical inertia of the pulleys, saw disks, mills. This switch has its ideal application where the guard is not opened frequently and the installation of a switch with solenoid would be too expensive.

These switches are considered interlocks with guard locking in accordance with ISO 14119, and the product is marked on the side with the symbol shown.



Head and knobs with variable orientation

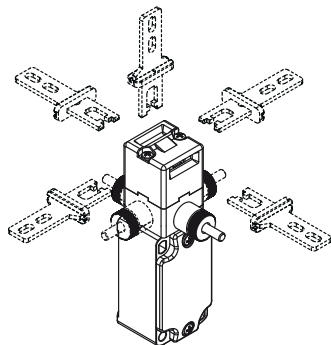

The head can be quickly turned to each of the four sides of the switch by unfastening the two fastening screws.

The mechanical delay device can be rotated in 90° steps as well. This enables the switch to assume 32 different configurations.

Adjustment range

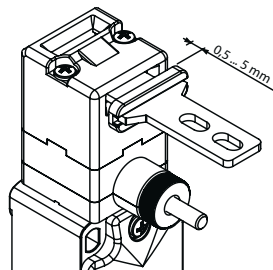

The actuation head of this switch features a wide range of travel. In this way the guard can oscillate along the direction of insertion (4.5 mm) without causing unwanted machine shutdowns. This wide range of travel is available in all actuators in order to ensure maximum device reliability.

Protection degree IP67

IP67 These devices are designed to be used in the toughest environmental conditions and they pass the IP67 immersion test acc. to EN 60529. They can therefore be used in all environments where maximum protection degree of the housing is required.

Contact block



Contact blocks with captive screws, finger protection, twin bridge contacts and double interruption for higher contact reliability. Available in multiple versions with shifted, simultaneous or overlapping actuation paths. They are suitable for many different applications.

Holding force of the unlocked actuator

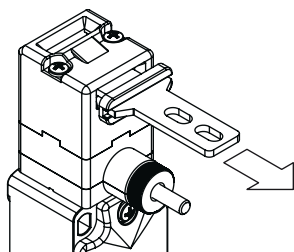

The inside of each switch features a device which holds the actuator in its closed position. Ideal for all those applications where several doors are unlocked simultaneously, but only one is actually opened. The device keeps all the unlocked doors in their position with a retaining force of 30 N~, stopping any vibrations or gusts of wind from opening them.

Extended temperature range

-40°C

These devices are also available in a special version suitable for an ambient operating temperature range from -40°C up to +80°C.

They can therefore be used for applications in cold stores, sterilisers and other equipment with low temperature environments. The special materials used to produce these versions retain their characteristics even under these conditions, thereby expanding the installation possibilities.

Laser engraving



All devices are marked using a dedicated indelible laser system. These engravings are therefore suitable for extreme environments too. Thanks to this system that does not use labels, the loss of plate data is prevented and a greater resistance of the marking is achieved over time.

Safety screws for actuators

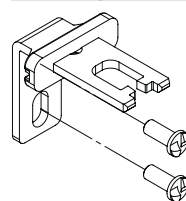

As required by EN ISO 14119, the actuator must be fixed immovably to the door frame. Pan head safety screws with one-way fitting are available for this purpose. With this screw type, the actuators cannot be removed or tampered by using common tools. See accessories on page 310.

Features approved by IMQ

| | |
|---|--|
| Rated insulation voltage (U _i): | 500 Vac 400 Vac (for contact blocks 20, 21, 22, 33, 34) |
| Conventional free air thermal current (I _{th}): | 10 A |
| Protection against short circuits: | type aM fuse 10 A 500 V |
| Rated impulse withstand voltage (U _{imp}): | 6 kV 4 kV (for contact blocks 20, 21, 22, 33, 34) |
| Protection degree of the housing: | IP67 |
| MV terminals (screw terminals) | |
| Pollution degree: | 3 |
| Utilization category: | AC15 |
| Operating voltage (U _e): | 400 Vac (50 Hz) |
| Operating current (I _e): | 3 A |

Forms of the contact element: Zb, Y+Y, Y+Y+X, Y+Y+Y, Y+X+X

Positive opening contacts on contact blocks 6, 7, 9, 20, 21, 22, 33, 34

In compliance with standards: EN 60947-1, EN 60947-5-1+ A1:2009, fundamental requirements of the Low Voltage Directive 2014/35/EU.

Please contact our technical department for the list of approved products.

Features approved by UL

| | |
|------------------------|---|
| Utilization categories | Q300 (69 VA, 125-250 Vdc) A600 (720 VA, 120-600 Vac) |
|------------------------|---|

Housing features type 1, 4X "indoor use only"; 12, 13
For all contact blocks use 60 or 75 °C copper (Cu) conductor, rigid or flexible, wire size 12, 14 AWG. Tightening torque for terminal screws of 7.1 lb in (0.8 Nm).

In compliance with standard: UL 508, CSA 22.2 No.14

Please contact our technical department for the list of approved products.

Operation (FP 6R2-M2F1)

The switch is fastened to the machine body (A), while the stainless steel actuator is fastened to the guard (B). Once installed, the switch will firmly lock the actuator. In order to remove the actuator, the knob (C) has to be rotated. On the first turns the electrical contacts will positively open, then, after about 20 seconds (or 10 seconds depending on the version), the actuator will be released. In order to close the guard, the knob must be rotated in the opposite direction. This switch doesn't need power supply or timer and can be easily installed on old machines without important changes in their electrical circuit. The knob (C) may be supplied in a short (standard) or in a long version.

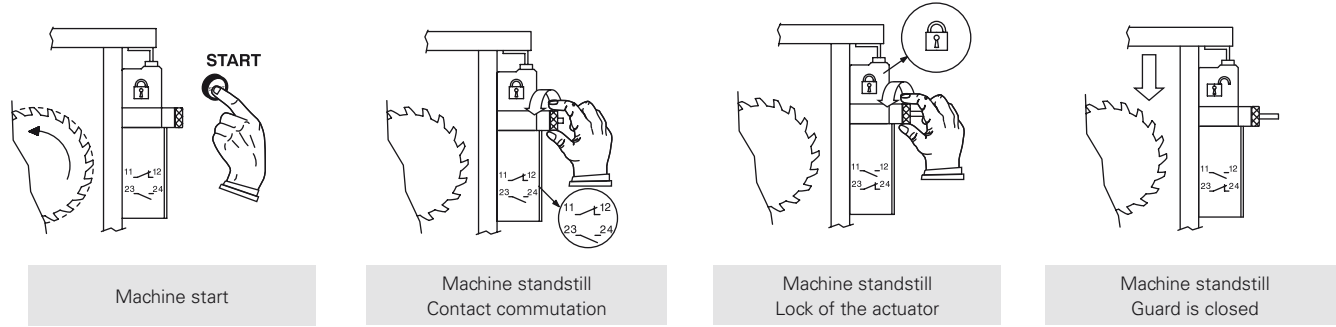
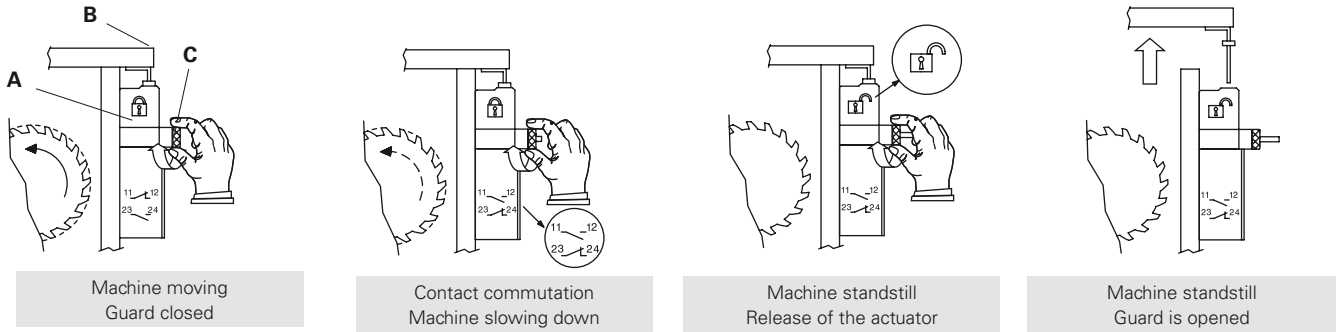

Operating phases (FD 6R2-M2F1)

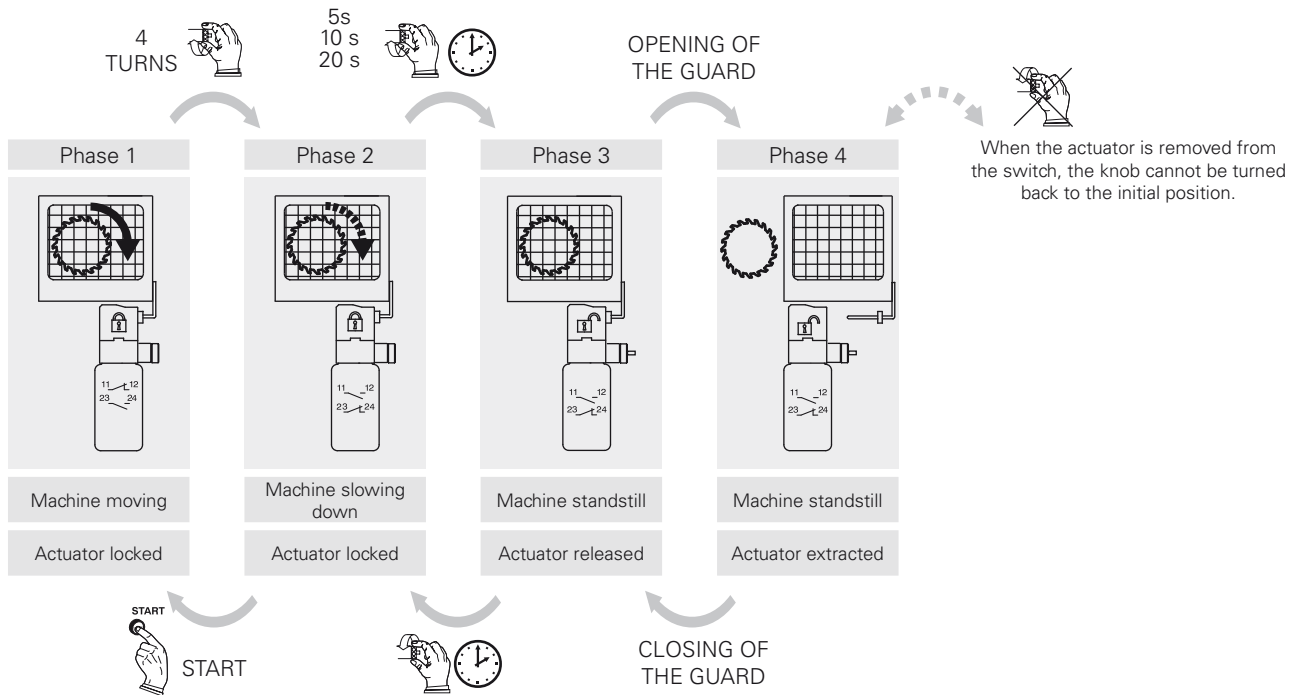



Dimensional drawings

All values in the drawings are in mm

Contact type:

L = slow action
LO = slow action, make before break

Contact block

| | Technopolymer housing Without actuator | Metal housing Without actuator | Metal housing Without actuator |
|-----------------|---|-----------------------------------|-----------------------------------|
| 6 | FP 6R2-M2 1NO+1NC | FD 6R2-M2 1NO+1NC | FD 6R2-L10M2 1NO+1NC |
| 7 | FP 7R2-M2 1NO+1NC | FD 7R2-M2 1NO+1NC | FD 7R2-L10M2 1NO+1NC |
| 9 | FP 9R2-M2 2NC | FD 9R2-M2 2NC | FD 9R2-L10M2 2NC |
| 20 | FP 20R2-M2 1NO+2NC | FD 20R2-M2 1NO+2NC | FD 20R2-L10M2 1NO+2NC |
| 21 | FP 21R2-M2 3NC | FD 21R2-M2 3NC | FD 21R2-L10M2 3NC |
| 22 | FP 22R2-M2 2NO+1NC | FD 22R2-M2 2NO+1NC | FD 22R2-L10M2 2NO+1NC |
| 33 | FP 33R2-M2 1NO+1NC | FD 33R2-M2 1NO+1NC | FD 33R2-L10M2 1NO+1NC |
| 34 | FP 34R2-M2 2NC | FD 34R2-M2 2NC | FD 34R2-L10M2 2NC |
| Actuating force | 10 N (18 N) | 10 N (18 N) | 10 N (18 N) |

All values in the diagrams are in turns of the knob

Legend: With positive opening according to EN 60947-5-1, interlock with lock monitoring acc. to EN ISO 14119

How to read travel diagrams

All values in the diagrams are in turns of the knob

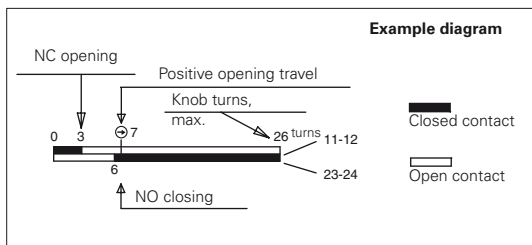

IMPORTANT:

The state of the NC contact refers to the switch with inserted actuator and with the knob turned anti-clockwise up to the end of the travel. For installation in safety applications, actuate the switch at least up to the positive opening travel shown in the travel diagrams with symbol . Actuate the switch at least with the positive opening force, reported in brackets below each article, next to the actuating force value.

Limits of use

Do not use where dust and dirt may penetrate in any way into the head and deposit there. Especially not where powder, shavings, concrete or chemicals are sprayed. Adhere to the EN ISO 14119 requirements regarding low level of coding for interlocks. Do not use in environments with presence of explosive or flammable gas. In these case use ATEX products (see dedicated Pizzato catalogue).

Attention! These switches alone are not suitable for applications where operators may physically enter the dangerous area, because an eventual closing of the door behind them could restart the machine operation. In these cases, the maintenance personnel must use the actuator entry locking device VF KB1 shown on page 144.

Items with code on green background are stock items

Accessories See page 299

The 2D and 3D files are available at www.pizzato.com

Stainless steel actuators

IMPORTANT: These actuators can be used only with items of the FD, FP, FL, FC and FS series (e.g. FD 6R2-M2).
Low level of coding acc. to EN ISO 14119.

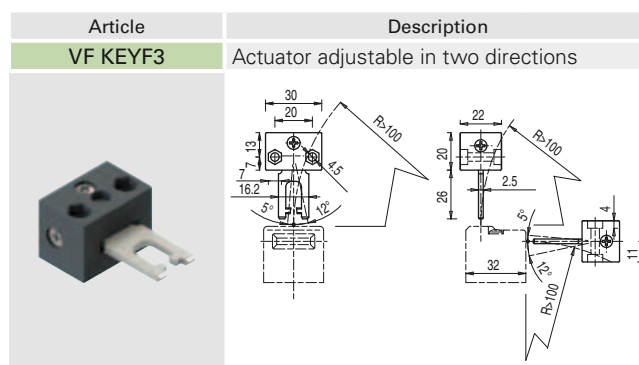
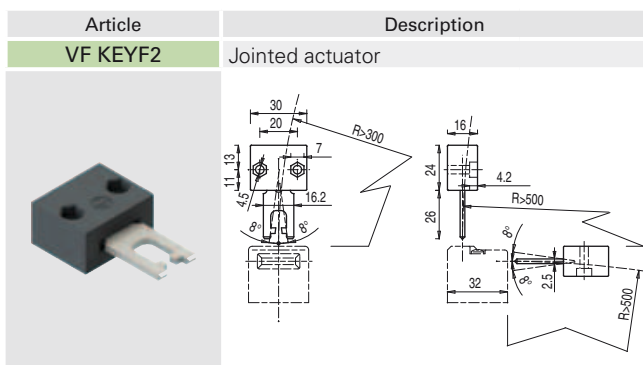
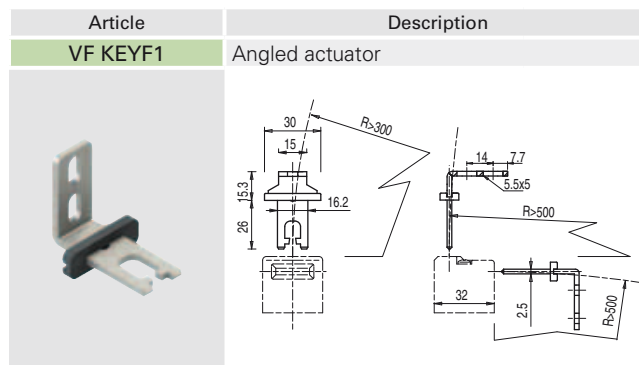
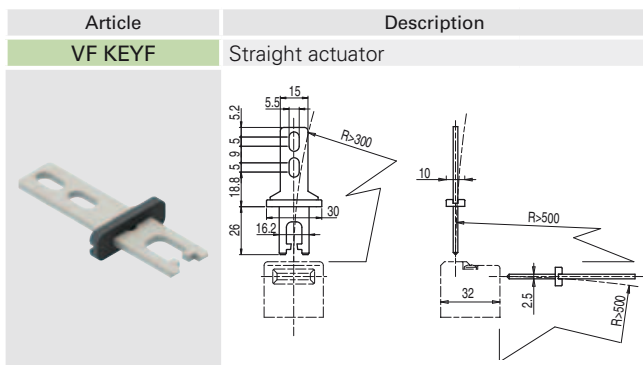

The actuator can flex in four directions for applications where the door alignment is not precise.

Actuator adjustable in two directions for doors with reduced dimensions.

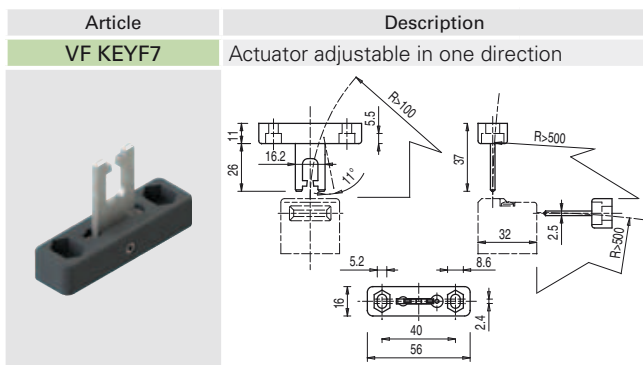

Actuator adjustable in one direction for doors with reduced dimensions.



Universal actuator VF KEYF8

IMPORTANT: These actuators can be used only with items of the FD, FP, FL, FC and FS series (e.g. FD 6R2-M2).
Low level of coding acc. to EN ISO 14119.

| Article | Description |
|----------|--------------------|
| VF KEYF8 | Universal actuator |

Actuator adjustable in two dimensions for small doors; can be mounted in various positions.
The fixing block has two pairs of bore holes; it is provided for rotating the working plane of the actuator by 90°.

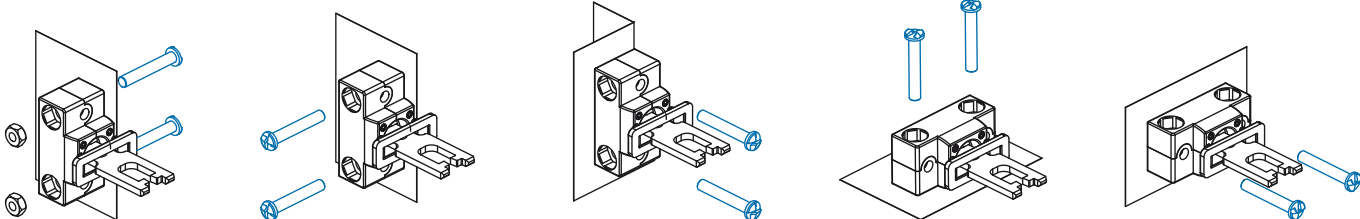
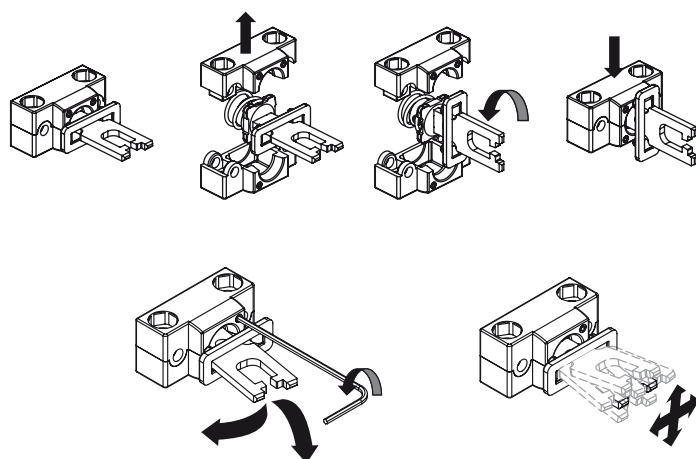

Accessories

| Article | Description |
|---------|-------------------------------|
| VF KB1 | Actuator entry locking device |

Padlockable device to lock the actuator entry in order to prevent the accidental closing of the door behind operators while they are in the danger area.
Hole diameter for padlocks: 9 mm.



Items with code on **green** background are stock items

Accessories See page 299

→ The 2D and 3D files are available at www.pizzato.com